

REPLACEMENT

NOTICE:

Be careful not to grip the propeller shaft tube too tightly in the vise as will cause deformation.

1. REPLACE CENTER SUPPORT BEARING

- (a) Using a chisel and hammer, unstake the staked part of the nut.
- (b) Mount the intermediate shaft sub-assembly in a vise.

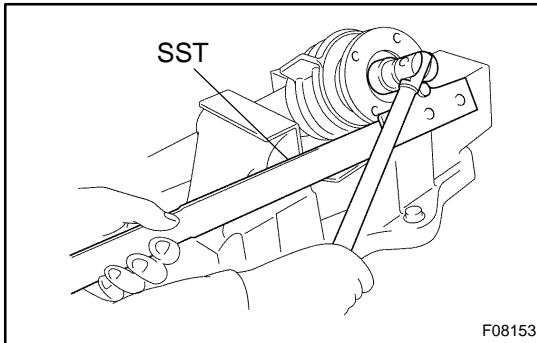

- (c) Using SST to hold the universal joint flange, remove the nut.

SST 09930-00021

- (d) Remove the washer plate.

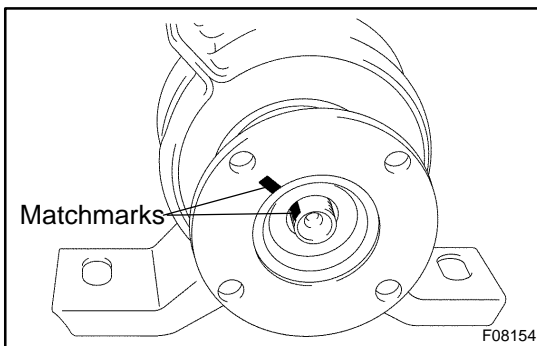

- (e) Place matchmarks on the universal joint flange and intermediate shaft.

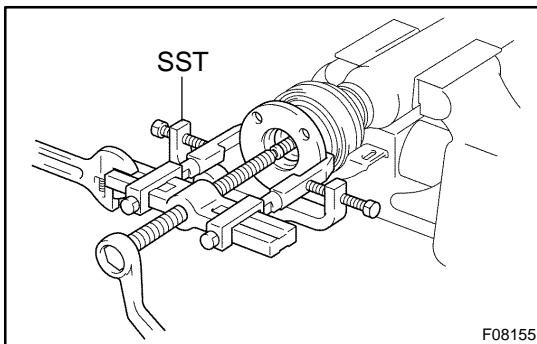

- (f) Using SST, remove the universal joint flange.

SST 09950-4001 1 (09951-04020, 09952-04010, 09953-04030, 09954-04010, 09955-04061, 09957-04010, 09958-04011)

- (g) Remove the 2 washers.
- (h) Remove the center support bearing.

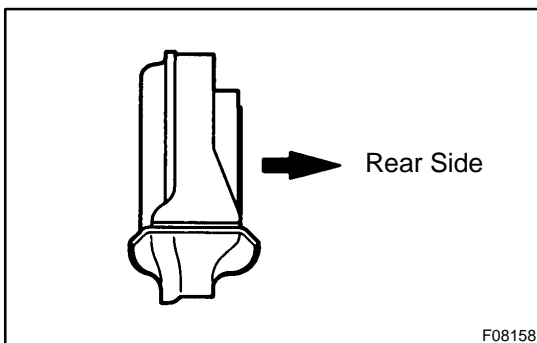

- (i) Install a new center support bearing to intermediate shaft.

HINT:

Install the center support bearing in the direction, as shown.

- (j) Install the 2 washers.

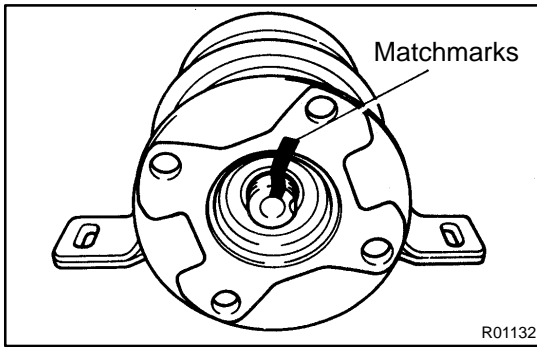

- (k) Align the matchmarks on the universal joint flange and intermediate shaft, and install the universal joint flange.

HINT:

If replacing either the center flange or intermediate shaft, reassemble them so that the front yoke of the intermediate shaft and the rear yoke of the propeller shaft are facing in the same direction.

- (l) Install the washer plate.

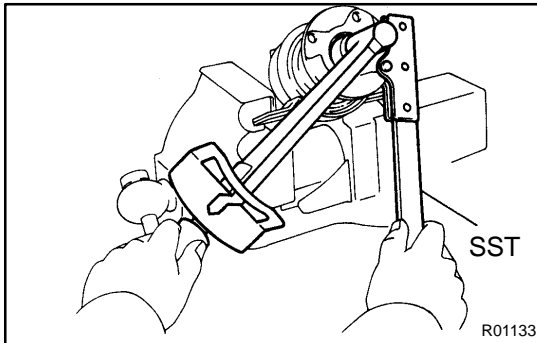

- (m) Using SST to hold the flange, install a new nut.

SST 09330-00021

Torque: 181 N·m (1,850 kgf·cm, 134 ft·lbf)

- (n) Loosen the nut.

- (o) Torque the nut again.

Torque: 69 N·m (700 kgf·cm, 51 ft·lbf)

- (p) Using a chisel and hammer, stake the nut.

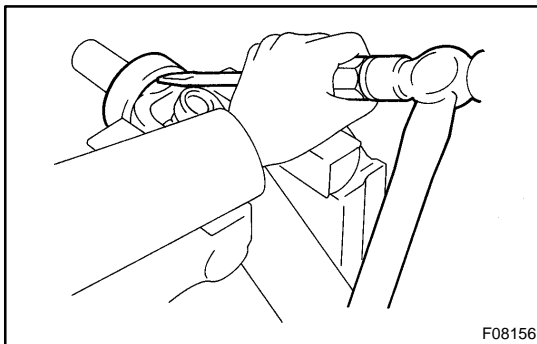

2. REPLACE DUST COVER

- (a) Mount the intermediate shaft sub-assembly in a vise.
 (b) Using a screwdriver and hammer, remove the dust cover.

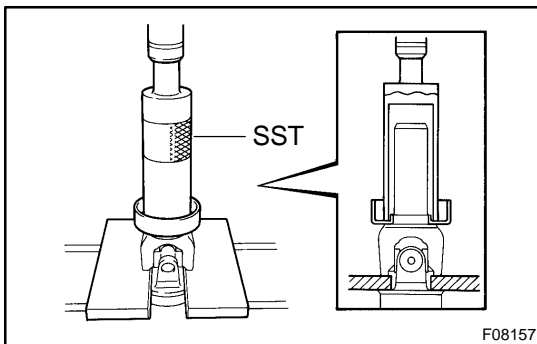

- (c) Using SST and press, install a new dust cover.

SST 09316-6001 1 (09316-00011)