

■ TRANSMISSION CASE

- A die-cast aluminum transmission case that integrates the torque converter housing and extension housing is adopted. As a result of the case construction, a lightweight and highly rigid case is achieved.
- A hydraulic cylinder chamber for the B₂ brake is provided in the back end of the transmission case in order to shorten the overall length of the transmission case.

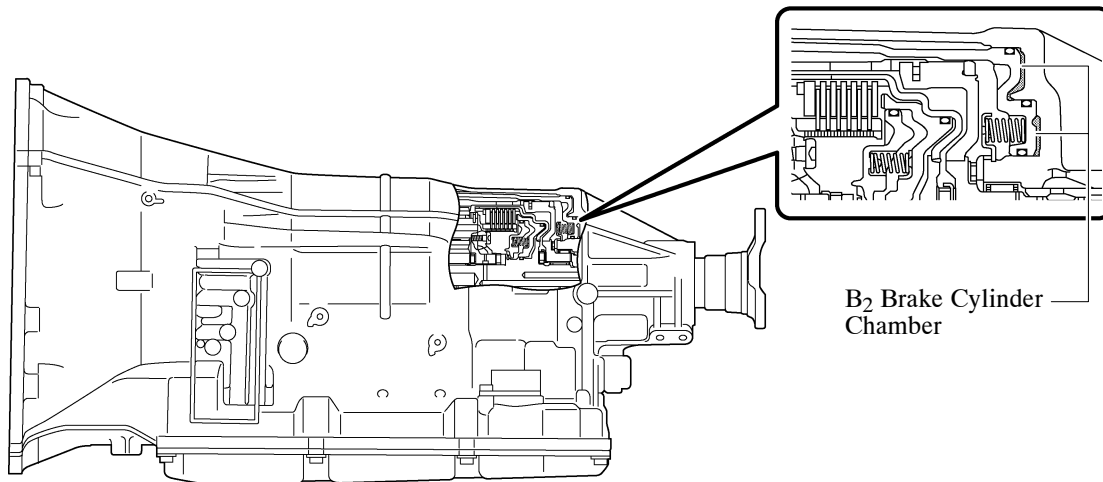

08D0CH13C

■ TORQUE CONVERTER CLUTCH ASSEMBLY

A compact, lightweight and high-capacity torque converter clutch assembly is used. The torque converter clutch assembly supports flex lock-up clutch control, thus improving fuel economy.

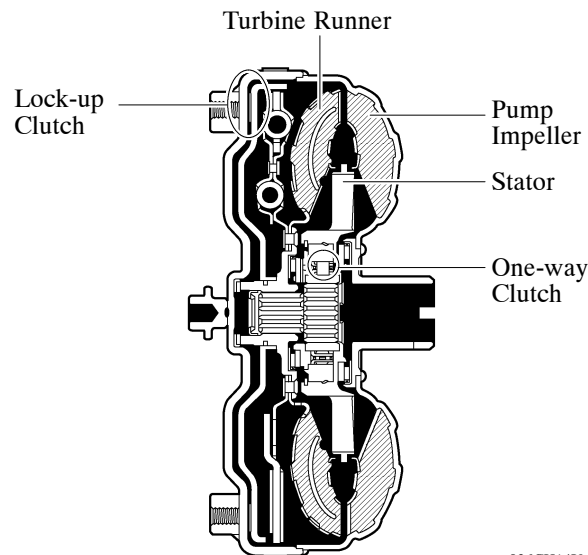

036CH14Y

► Specifications ◀

Torque Converter Type	3-Element, 1-Step, 2-Phase
Stall Torque Ratio	1.83